

FUA

FUA-1300/1800/2100/3000/4700

The FUA is an extraction fan that is specially designed to remove welding and other harmful fumes as dust, oil mist and exhaust gases.

The fan is intended and designed for mounting to extraction arms and filter units.



APPLICATIONS

The FUA is intended to be used for the following applications:

- MIG-MAG/GMAW welding
- TIG welding
- FCAW welding
- stick/MMAW welding
- vehicle exhaust extraction systems



Do **not** use the FUA for the following applications or in the following circumstances:

- arc-air gouging
- oxy-fuel cutting
- aluminium laser cutting
- extraction of aggressive fumes and gases (e.g. from acids, alkaline or soldering paste containing lithium)
- extraction of hot gases (more than 40°C/104°F continuously)
- grinding aluminium and magnesium
- flame spraying
- extraction of cement, saw dust, wood dust, etc.
- explosive environments or explosive substances/gases



SPECIFICATIONS

■ Physical dimensions and properties

Material:	<ul style="list-style-type: none"> • fan • housing 	<ul style="list-style-type: none"> • aluminium • sheet metal
Colour:	<ul style="list-style-type: none"> • motor • housing 	<ul style="list-style-type: none"> • black (RAL 9005) • grey (RAL 7035)
Motor design	IEC 60072	
Fan type	radial	
Design conditions	20°C (68°F) at sea level	

■ Performance

Speed	2800 rpm
-------	----------

■ Electrical data

Max. start/stops per hour	30
Insulation class	F
Protection class	IP 55

■ Ambient conditions

Operating temperature:	<ul style="list-style-type: none"> • min. 5°C (41°F) • nom. 20°C (68°F) • max. 40°C (104°F)
Max. relative humidity	80%
Outdoor use allowed	no
Storage conditions	<ul style="list-style-type: none"> • 5-40°C (41-104°F) • relative humidity max. 80%

■ Product combinations

Exhaust extraction systems	all hose reel/dropper systems
Filter units	all systems
Fume extraction systems	all systems
Control equipment	all systems

■ Scope of supply

Fan	
-----	--

■ Order information

Number/package	1
----------------	---

■ Shipping data

Harmonized Tariff Code	8414.5940.90
Country of origin	the Netherlands

See table 1: for dimensions.

See table 2: for remaining specifications, options and accessories.

See page 2: for outlet and motor positions.

See page 4: for fan curves.

APPROVALS/CERTIFICATES

	Directive 2011/65/EC (RoHS) valid as of 8 June 2011

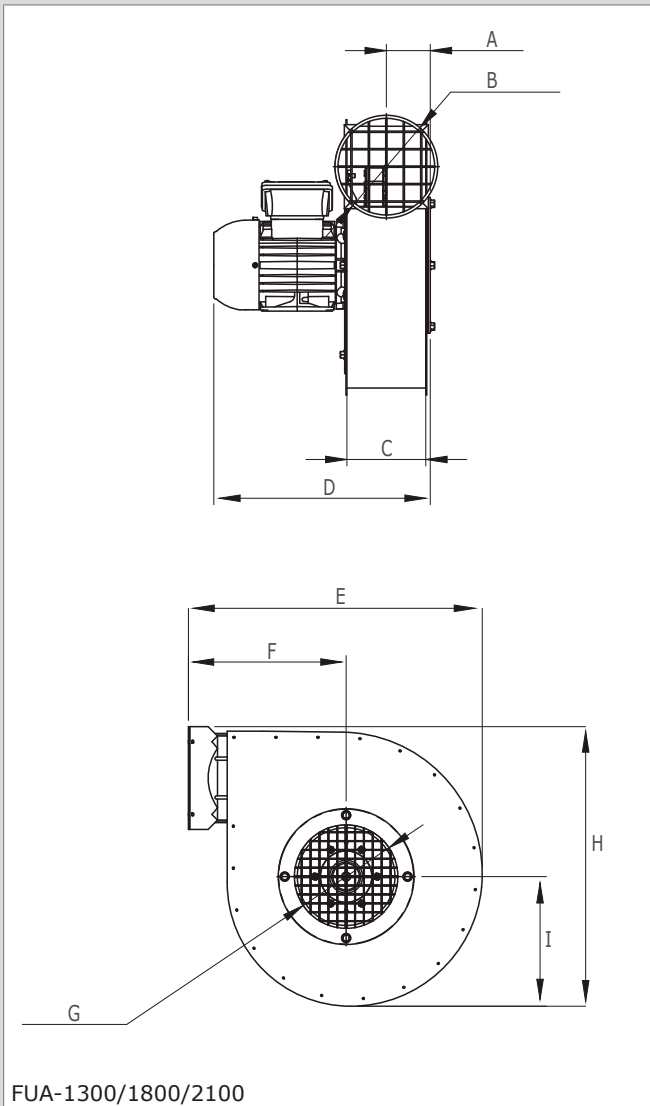

FUA-1300/1800/2100

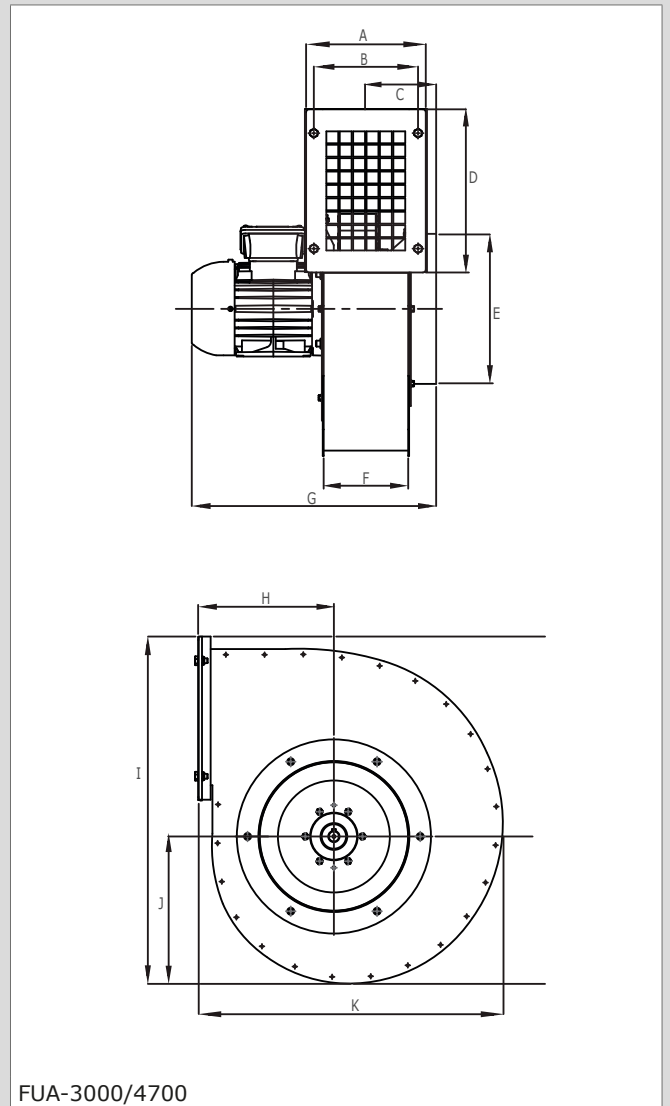

FUA-3000/4700

Table 1: Dimensions

	FUA-1300/1800	FUA-2100
A	68 mm (2.7 in.)	68 mm (2.7 in.)
B	Ø 159 mm (6.3 in.)	Ø 159 mm (6.3 in.)
C	122 mm (4.8 in.)	122 mm (4.8 in.)
D	335 mm (13.2 in.)	353 mm (13.9 in.)
E	455 mm (17.9 in.)	455 mm (17.9 in.)
F	244 mm (9.6 in.)	244 mm (9.6 in.)
G	Ø 160 mm (6.3 in.)	Ø 160 mm (6.3 in.)
H	433 mm (17 in.)	433 mm (17 in.)
I	201 mm (7.9 in.)	201 mm (7.9 in.)
Fan wheel (not shown)		
- diameter	300 mm (Ø 11.8 in.)	Ø 300 mm Ø 11.8 in.)
- width	20 mm (0.8 in.)/ 25 mm (1.0 in.)	60 mm (2.4 in.)

DISCHARGE AND MOTOR POSITIONS

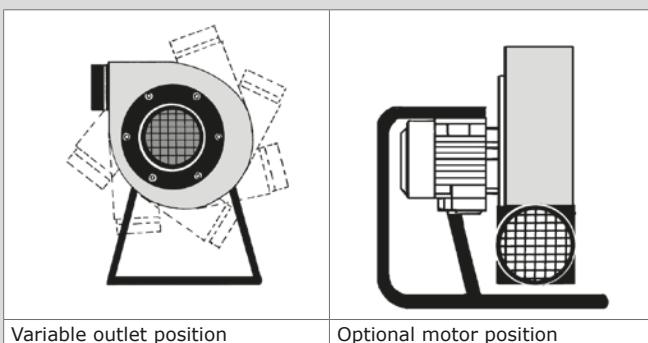

Variable outlet position

Optional motor position

	FUA-3000	FUA-4700
A	201 mm (7.9 in.)	205 mm (8.1 in.)
B	175 mm (6.9 in.)	175 mm (6.9 in.)
C	118 mm (4.6 in.)	117 mm (4.6 in.)
D	274 mm (10.8 in.)	348 mm (13.7 in.)
E	Ø 250 mm (9.8 in.)	Ø 245 mm (9.6 in.)
F	142 mm (5.6 in.)	142 mm (5.6 in.)
G	410 mm (16.1 in.)	472 mm (18.6 in.)
H	228 mm (9 in.)	258 mm (10.6 in.)
I	583 mm (23 in.)	733 mm (28.9 in.)
J	247 mm (9.7 in.)	297 mm (11.7 in.)
K	512 mm (20.2 in.)	591 mm (23.3 in.)
Fan wheel (not shown)		
- diameter	Ø 320 mm (12.6 in.)	Ø 380 mm (15 in.)
- width	60 mm (2.4 in.)	45 mm (1.8 in.)

Product type	FUA
Article no.	see order information
Product category	extraction fan
Version	160712/0

Always check the latest version on www.plymovent.com.

Table 2: Remaining specifications and available options and accessories

Features	FUA-1300		FUA-1800	FUA-2100		FUA-3000	FUA-4700
	230V	230-400V	230-400V	230V	230-400V	230-400V	230-400V
Article number	0000100300	0000100302	0000100303	0000100301	0000100304	0000100306	0000100308
■ Weight							
Net weight	12,8 kg (28.2 lbs)	11,9 kg (26.2 lbs)	12,3 kg (27.1 lbs)	16,5 kg (36.4 lbs)	16,4 kg (36.2 lbs)	21,9 kg (48.3 lbs)	34,5 kg (76.1 lbs)
■ Electrical data							
Connection voltages	230V/ 1~/50Hz	230-400V/ 3~/50Hz	230-400V/ 3~/50Hz	230V/ 1~/50Hz	230-400V/ 3~/50Hz	230-400V/ 3~/50Hz	230-400V/ 3~/50Hz
Power consumption	0,37 kW (0.5 HP)	0,37 kW (0.5 HP)	0,55 kW (0.75 HP)	0,75 kW (1 HP)	0,75 kW (1 HP)	1,1 kW (1.5 HP)	2,2 kW (3 HP)
Nominal current - 230V - 400V	2,75 A -	- 1,1/1,02 A	- 1,5/1,4 A	5 A -	- 2/1,9 A	- 2,7/2,5 A	- 4,9/4,8 A
■ Performance							
Noise level dB(A) (pressure and suction side duct connected)	63	63	63,8	65,9	65,9	68,1	75,9
■ Options and accessories							
<i>Fan on/off manually (wall)</i> Motor starter with overload: - overload 230V/3~/50Hz - overload 400V/3~/50Hz	ECMSO-4 -	ECMSO-2,5 ECMSO-1,6	ECMSO-2,5 ECMSO-1,6	ECMSO-6,3 -	ECMSO-4 ECMSO-2,5	ECMSO-6,3 ECMSO-2,5	ECMSO-10 ECMSO-6,3
<i>Fan on/off manually (on hood of extraction arm)</i> - starter for fan and working light - overload 230V/3~/50Hz - overload 400V/3~/50Hz	SA-24-75 MS-2.3/3.2 -	SA-24-75 MS-1.4/2.0 MS-0.9/1.3	SA-24-75 MS-2.3/3.2 MS-0.9/1.3	SA-24-75 MS-4.5/6.3 -	SA-24-75 MS-2.3/3.2 MS-1.4/2.0	SA-24-75 MS-4.5/6.3 MS-2.3/3.2	SA-24-75 MS-7.2/10 MS-4.5/6.3
<i>Fan on/off automatically (inductive sensor)</i> - starter for fan and working light - overload 230V/3~/50Hz - overload 400V/3~/50Hz	ES-90-005 MS-2.3/3.2 -	ES-90-005 MS-1.4/2.0 MS-0.9/1.3	ES-90-005 MS-2.3/3.2 MS-0.9/1.3	ES-90-005 MS-4.5/6.3 -	ES-90-005 MS-2.3/3.2 MS-1.4/2.0	ES-90-005 MS-4.5/6.3 MS-2.3/3.2	ES-90-005 MS-7.2/10 MS-4.5/6.3
<i>Fan on/off automatically (light sensor)</i> - starter for fan and working light - light sensor - overload 230V/3~/50Hz - overload 400V/3~/50Hz	ES-90-005 LS-12 MS-2.3/3.2 -	ES-90-005 LS-12 MS-1.4/2.0 MS-0.9/1.3	ES-90-005 LS-12 MS-2.3/3.2 MS-0.9/1.3	ES-90-005 LS-12 MS-4.5/6.3 -	ES-90-005 LS-12 MS-2.3/3.2 MS-1.4/2.0	ES-90-005 LS-12 MS-4.5/6.3 MS-2.3/3.2	ES-90-005 LS-12 MS-7.2/10 MS-4.5/6.3
Mounting bracket stand (for free standing or mounting on wall, ceiling or platform)	MB-FUA/S1	MB-FUA/S1	MB-FUA/S1	MB-FUA/S1	MB-FUA/S1	MB-FUA/S2	MB-FUA/S2
Mounting bracket crane (for mounting on UK or FlexMax)	-	-	MB-FUA/C1	MB-FUA/C1	MB-FUA/C1	MB-FUA/C2	-
Outlet - Ø 250 mm - Ø 315 mm	- -	- -	- -	- -	- -	OL-250 -	OL-250 OL-315
■ Shipping data							
Gross weight	14,9 kg (32.9 lbs)	13,9 kg (30.4 lbs)	14,4 kg (31.8 lbs)	18,5 kg (40.8 lbs)	18,5 kg (40.8 lbs)	26 kg (57.3 lbs)	43,5 kg (95.9 lbs)
Packing dimensions	470 x 470 x 515 mm (18.5 x 18.5 x 20.3 in.)	470 x 470 x 515 mm (18.5 x 18.5 x 20.3 in.)	470 x 470 x 515 mm (18.5 x 18.5 x 20.3 in.)	470 x 470 x 515 mm (18.5 x 18.5 x 20.3 in.)	470 x 470 x 515 mm (18.5 x 18.5 x 20.3 in.)	590 x 590 x 480 mm (23.3 x 23.3 x 18.9 in.)	860 x 750 x 630 mm (33.9 x 29.5 x 24.8 in.)

FAN CURVES

